

ADVANTAGE POP UP SYSTEM BUNDLE KITS

POP UP SYSTEMS

POP UP SYSTEMS



Rapid assembly

Smooth seamless appearance

Complete display solution

pop up systems



ADVANTAGE 3x3

THE PLEX ADVANTAGE OFFERS A SEAMLESS GRAPHIC DISPLAY WALL. **LIGHTWEIGHT AND STRONG ALUMINIUM FRAME** IN A STRIKING BLACK FINISH. FEATURES INCLUDE **AUTO SET UP MAGNETIC LOCKING ARMS** AND **QUICK FIT MAGNETICALLY ATTACHED PANELS**.

EACH KIT COMES COMPLETE WITH **LIGHTS, POP UP CASE AND LECTERN CONVERSION KIT AS STANDARD**. IDEAL FOR EXHIBITIONS AND POINT OF SALE OR RETAIL ENVIRONMENTS.

QUICK AND EASY TO SET UP, THE ADVANTAGE WILL GIVE YOUR BUSINESS OR EVENT THE **PROFESSIONAL IMAGE** AT AN **AFFORDABLE PRICE**.

pop up systems

ADVANTAGE 3X3 ASSEMBLY INSTRUCTIONS

A

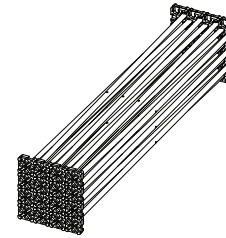

Unpack the collapsed frame from the drawstring bag

B

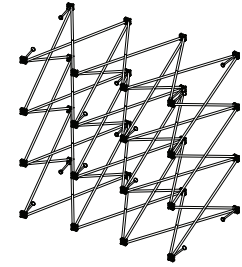

Extend the frame

C

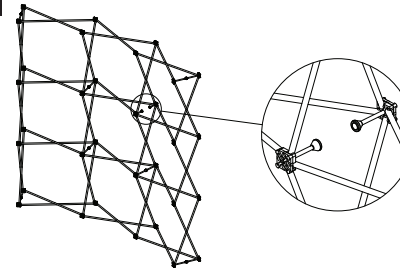

Magnetic locking arms will engage at full extension

D

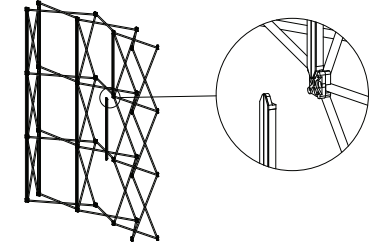

Attach mag bars to nodes

E

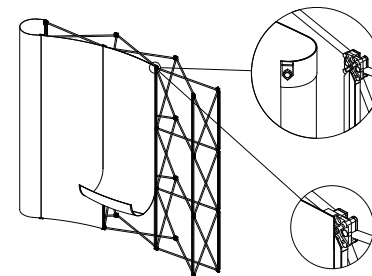

Attach panels in sequence to the mag bars starting at the top and smoothing down each side

F

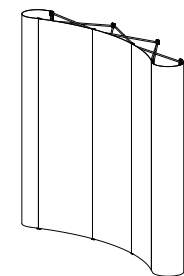

Assembled pop up system

LIGHT FITTING INSTRUCTIONS

1

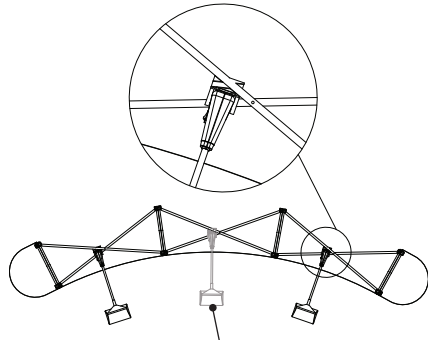

3rd light available as an optional extra

2

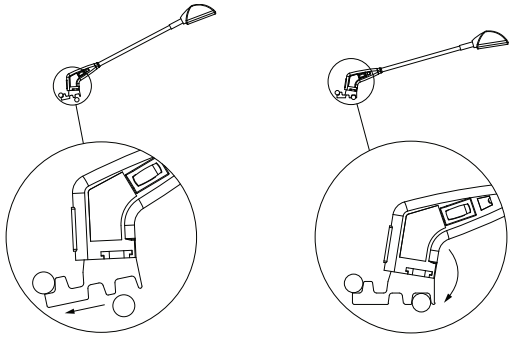

3

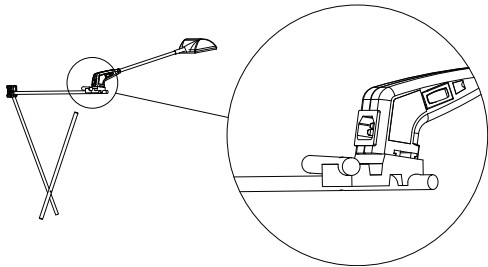

LECTERN WRAP ASSEMBLY INSTRUCTIONS

FABRIC WRAP (INCLUDED)

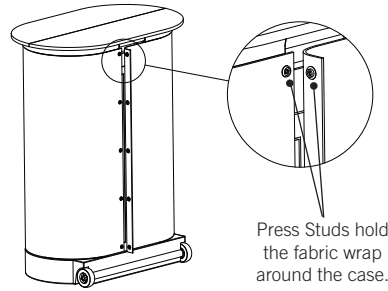

Press Studs hold the fabric wrap around the case.

GRAPHIC WRAP

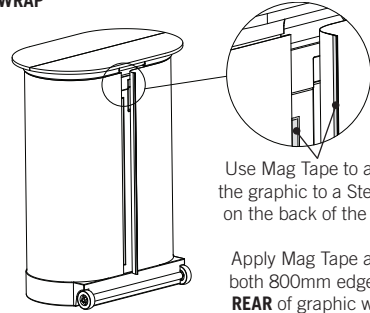

Use Mag Tape to attach the graphic to a Steel Bar on the back of the case.

Apply Mag Tape along both 800mm edges on **REAR** of graphic wrap.

CASE LID LIGHTING STORAGE

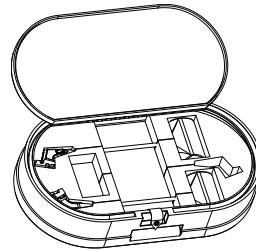

Halogen spotlights are stored in a protective case with space for an optional third spotlight.

PREPARING GRAPHIC ATTACHMENT

FRONT (2130 (H) x 653 (W) mm) / REAR PANEL (2130 (H) x 757 (W) mm)

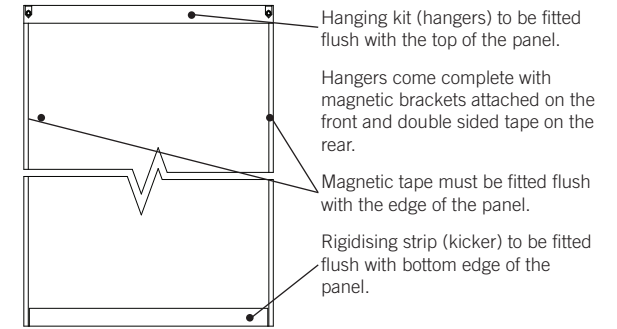

Hanging kit (hangers) to be fitted flush with the top of the panel.

Hangers come complete with magnetic brackets attached on the front and double sided tape on the rear.

Magnetic tape must be fitted flush with the edge of the panel.

Rigidising strip (kicker) to be fitted flush with bottom edge of the panel.

END PANEL (2130 (H) x 653 (W) mm)

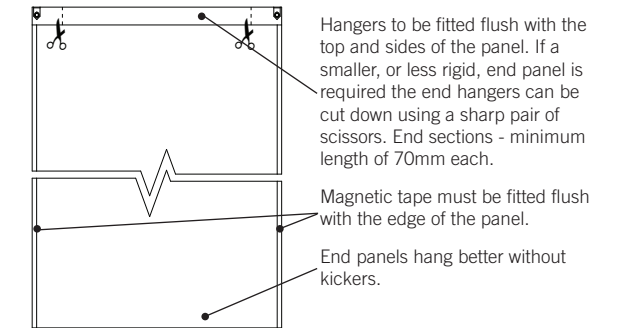

Hangers to be fitted flush with the top and sides of the panel. If a smaller, or less rigid, end panel is required the end hangers can be cut down using a sharp pair of scissors. End sections - minimum length of 70mm each.

Magnetic tape must be fitted flush with the edge of the panel.

End panels hang better without kickers.

CASE GRAPHIC WRAP (800 (H) x 1725* (W) mm)

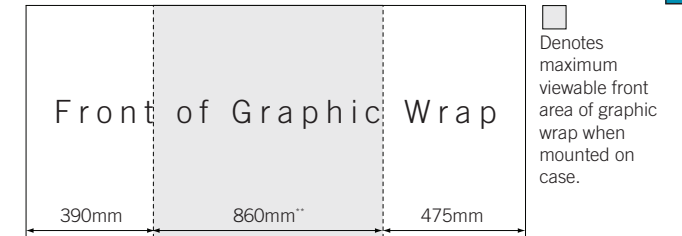

* Graphic size is only to be used as a guide. Case size may vary due to moulding process. Each Graphic should be made to suit the individual case.

**Please note: Image area is offset from centre of wrap.

ADVANTAGE 3x4

THE PLEX ADVANTAGE OFFERS A SEAMLESS GRAPHIC DISPLAY WALL. **LIGHTWEIGHT AND STRONG ALUMINIUM FRAME** IN A STRIKING BLACK FINISH. FEATURES INCLUDE **AUTO SET UP MAGNETIC LOCKING ARMS** AND **QUICK FIT MAGNETICALLY ATTACHED PANELS**.

EACH KIT COMES COMPLETE WITH **LIGHTS, POP UP CASE AND LECTERN CONVERSION KIT AS STANDARD**. IDEAL FOR EXHIBITIONS AND POINT OF SALE OR RETAIL ENVIRONMENTS.

QUICK AND EASY TO SET UP, THE ADVANTAGE WILL GIVE YOUR BUSINESS OR EVENT THE **PROFESSIONAL IMAGE** AT AN **AFFORDABLE PRICE**.

pop up systems

ADVANTAGE 3x4 ASSEMBLY INSTRUCTIONS

A

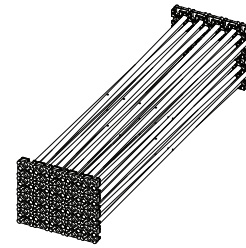

Unpack the collapsed frame from the drawstring bag

B

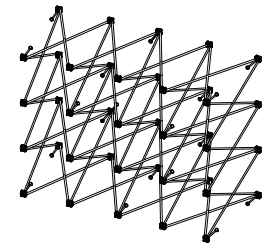

Extend the frame

C

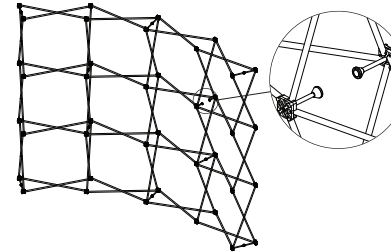

Magnetic locking arms will engage at full extension

D

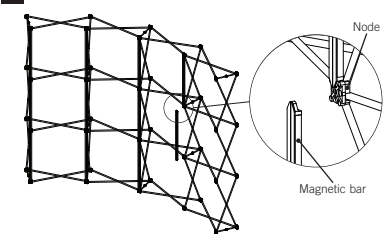

Attach mag bars to nodes

E

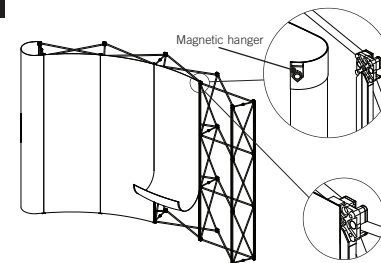

Attach panels in sequence to the mag bars starting at the top and smoothing down each side

F

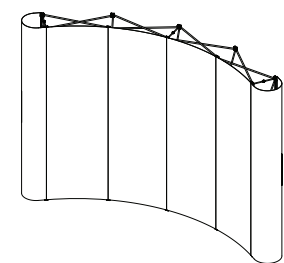

Assembled pop up system

LIGHT FITTING INSTRUCTIONS

1

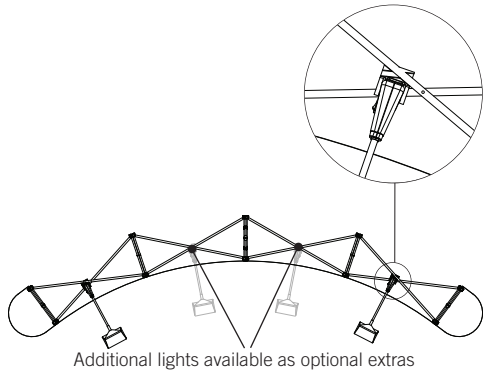

2

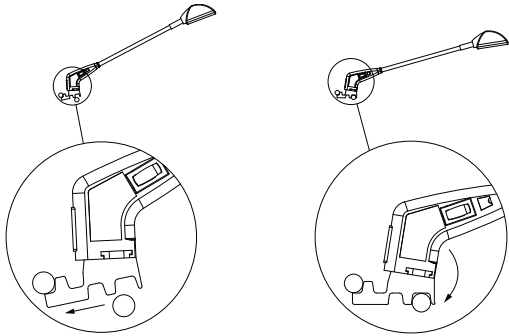

3

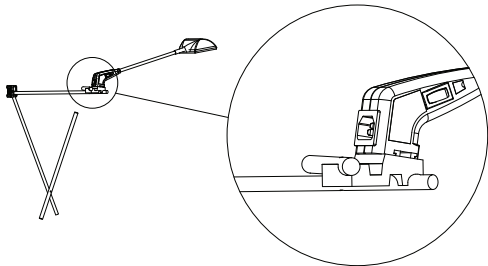

LECTERN WRAP ASSEMBLY INSTRUCTIONS

FABRIC WRAP (INCLUDED)

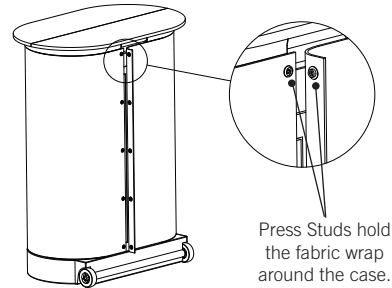

GRAPHIC WRAP

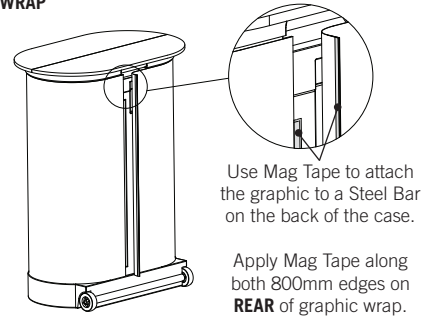

CASE LID LIGHTING STORAGE

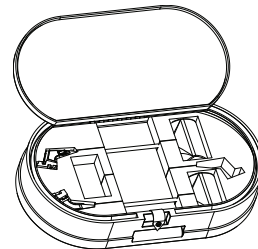

Halogen spotlights are stored in a protective case with space for an optional third spotlight.

PREPARING GRAPHIC ATTACHMENT

FRONT (2130 (H) x 653 (W) mm) / REAR PANEL (2130 (H) x 757 (W) mm)

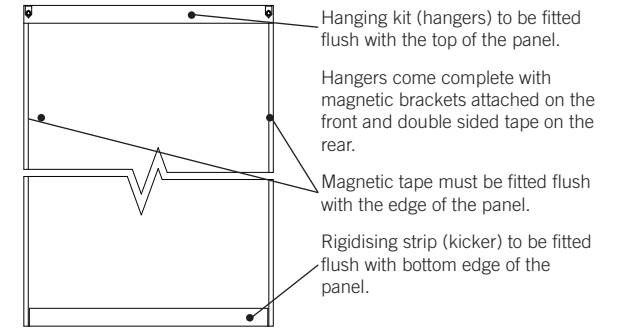

END PANEL (2130 (H) x 653 (W) mm)

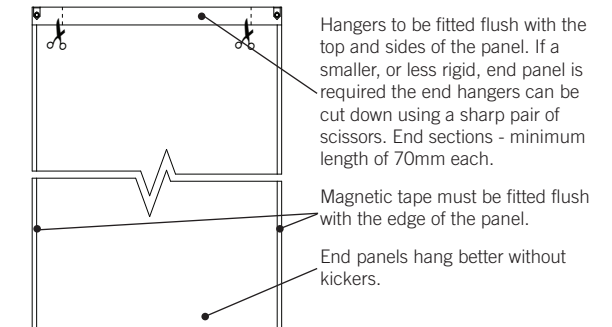

CASE GRAPHIC WRAP (800 (H) x 1725* (W) mm)

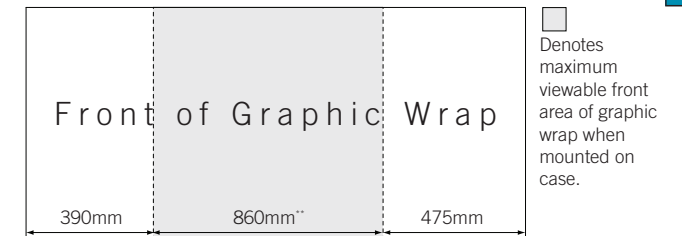

* Graphic size is only to be used as a guide. Case size may vary due to moulding process. Each Graphic should be made to suit the individual case.

**Please note: Image area is offset from centre of wrap.

SPECIFICATIONS

Graphic Panel Sizes

Front - 2130 x 653mm
 Rear - 2130 x 757mm
 D-End - 2130 x 653mm

System Sizes and weights

Boxed Size - 947 (H) x 663 (W) x 385 (D) mm
 Boxed Weight - 33kg
 Assembled - 2130 (H) x 2492 (W) x 596 (D) mm

3x3 COMPONENT LIST

- 1 - Black Wheeled Case
- 1 - 3x3 Curved Frame
- 1 - Frame Bag
- 18 - Aluminium Mag Bars
- 1 - Mag Bar Bag
- 5 - Panel Hangers
- 3 - Panel Kickers
- 1 - Roll Mag Tape
- 1 - Black Lectern Conversion Wrap
- 1 - Beech Laminate Lectern Conversion Top
- 2 - 220v 150w Halogen Lights, Brackets, Power Leads

Complete Advantage 3x3 Kit - Part No: 30266

3x4 COMPONENT LIST

- 1 - Black Wheeled Case
- 1 - 3x4 Curved Frame
- 1 - Frame Bag
- 21 - Aluminium Mag Bars
- 1 - Mag Bar Bag
- 6 - Panel Hangers
- 4 - Panel Kickers
- 1 - Roll Mag Tape
- 1 - Black Lectern Conversion Wrap
- 1 - Beech Laminate Lectern Conversion Top
- 2 - 220v 150w Halogen Lights, Brackets, Power Leads

Complete Advantage 3x4 Kit - Part No: 30316

EXTRAS / REPLACEMENTS

DESCRIPTION	PART No.
Aluminium Mag Bar	90867
Panel Hanger - Front / D-End	90868
Panel Kicker	90869
Reverse Curve Panel Hanger	90874
Reverse Curve Panel Kicker	90875
Halogen Light 220v 150w	90715
Mag Tape	390025

PANEL INFORMATION

Graphic panels for pop up systems can be produced on a wide range of substrate materials. Usual methods are a paper print with a clear front protective laminate and a lightstop backing, so the print is totally encapsulated.

An alternative method is to print on an inkjet receptive plastic sheet which is front laminated for protection.

We recommend you consult your substrate materials supplier regarding suitable materials for your particular brand of large format printer.

After applying the hangers, kickers and magnetic tape leave the panel flat for 24 hours to allow the adhesive to cure.

When storing fabric or graphic panels always roll them up with the magnetic tape on the inner surface.

Graphic panels supplied by Plex Display are 480 micron PVC covered in a choice of Fronrunner, Prelude or Loop Nylon. The hangers, kickers and magnetic tape are supplied attached to the panel.

OPTIONAL EXTRAS / REPLACEMENTS

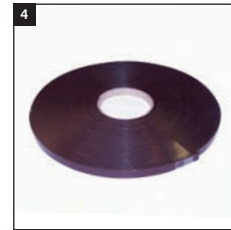

1. Halogen Light 220v 150w
2. Aluminium Mag Bar
3. Magnetic Panel Hanger - Front / D-End
4. Magnetic Tape Roll

SYSTEM COMPONENTS



1. Frame
2. Drawstring Frame Bag
3. Mag Bars x 18 (3x3) or 21 (3x4)
4. Mag Bar Bag
5. Mag Tape
6. Transit Case
7. Beech Lectern Top
8. Case Light Storage Lid
9. 220v 150w Halogen Lights x 2
10. Lectern Fabric Graphic Wrap

CAUTIONARY NOTE

If lifting the Advantage case (when full) please follow health and safety guidelines.